

3RD ANGLE PROJECTIONS

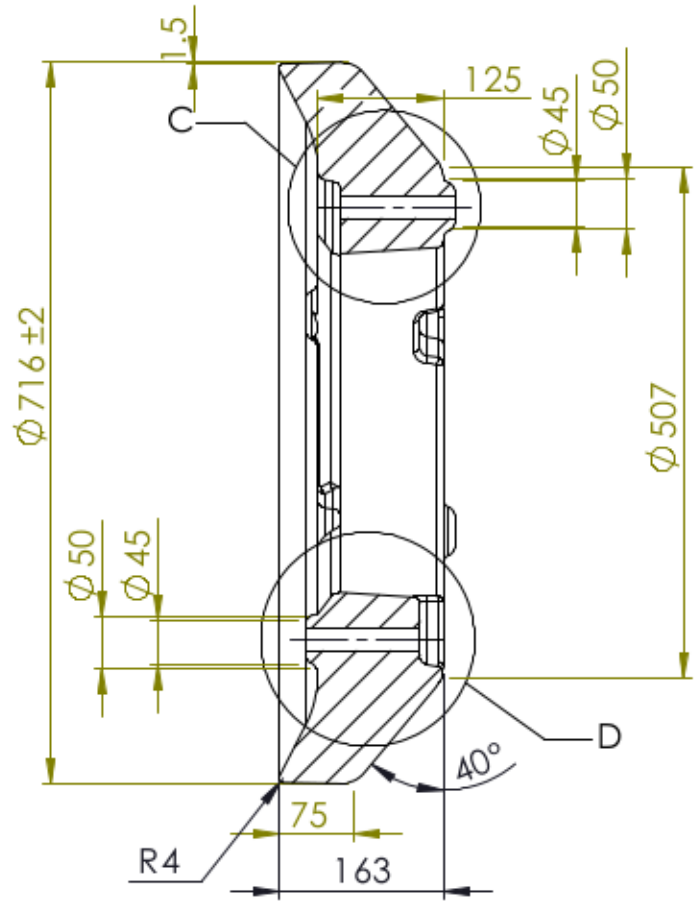

SECTION A-A

Section A-A. B, C, omitted this drawing

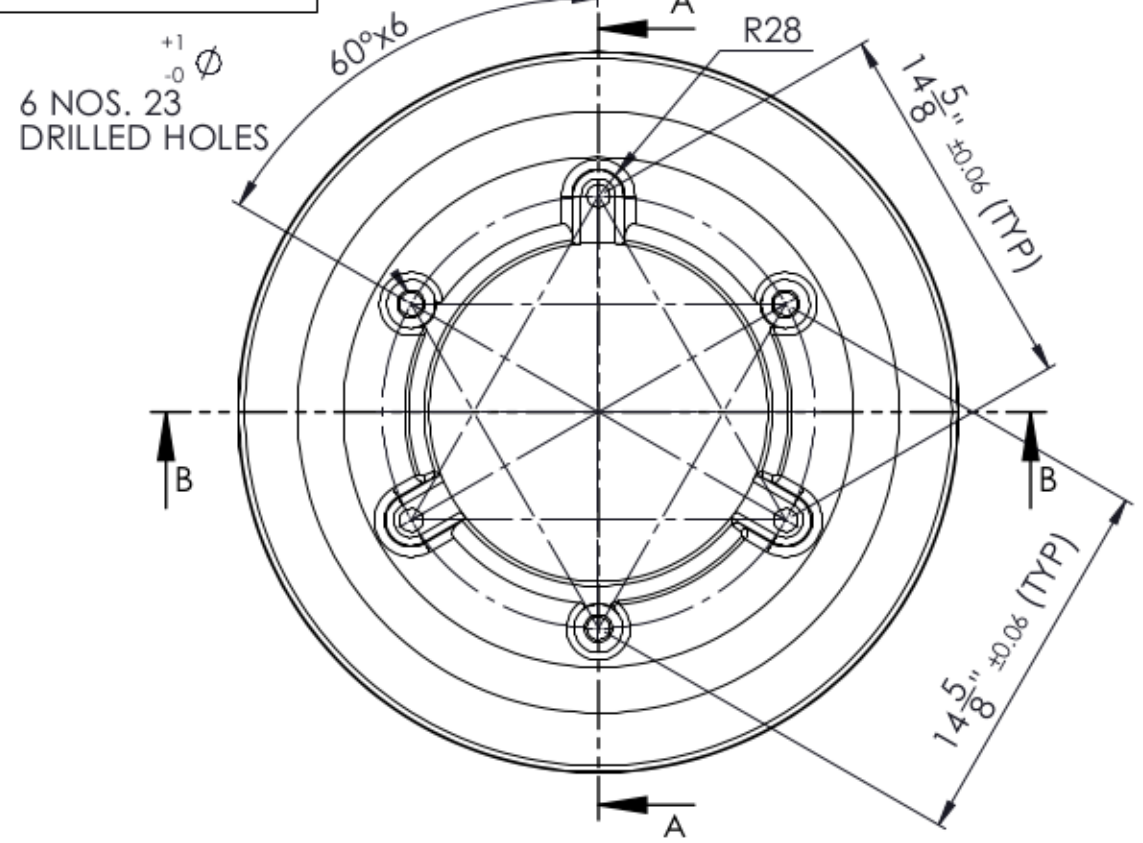
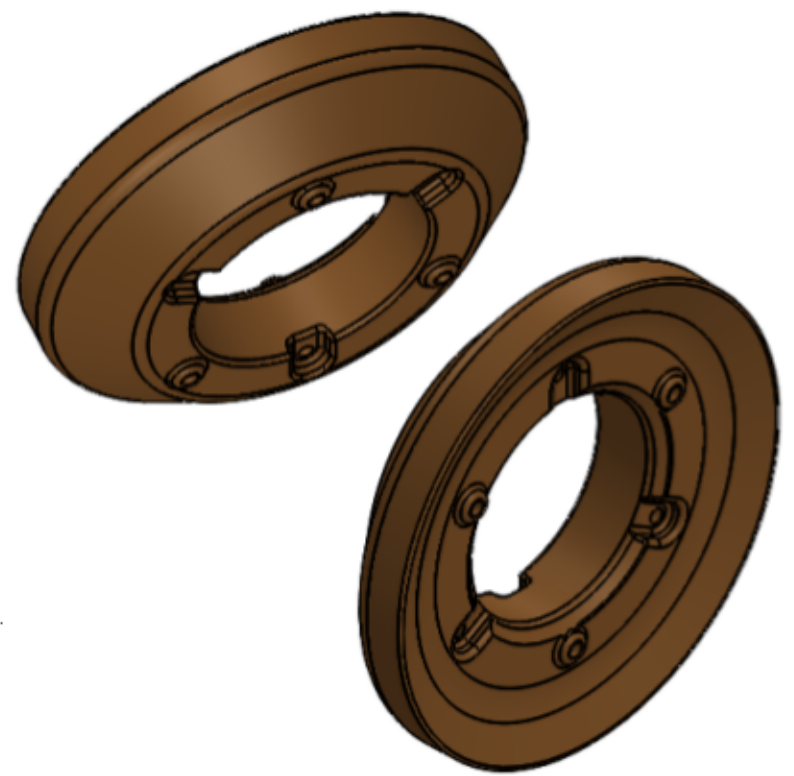

Requires 30" or larger wheel with correct mounting hole pattern.
All stated drawing dimensions are in mm.

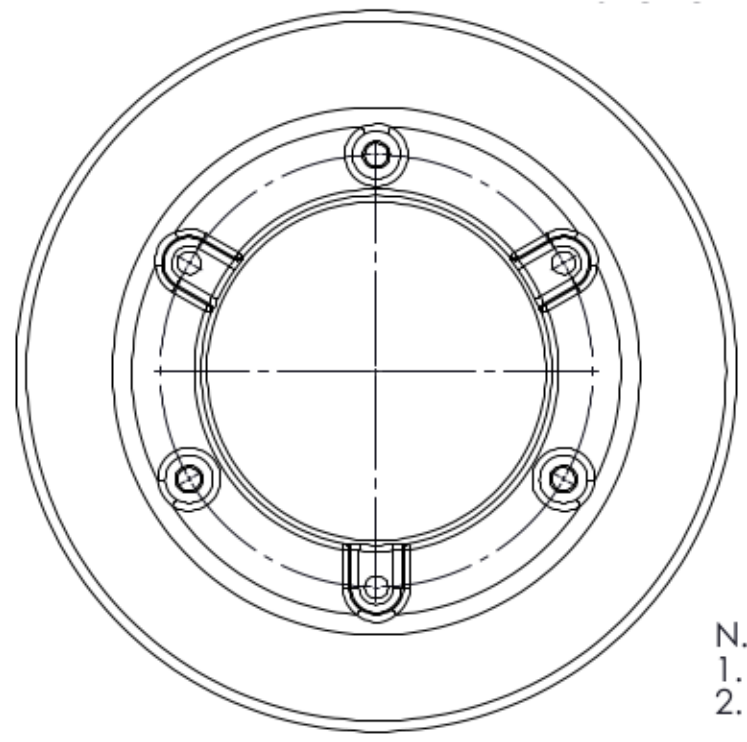

BOTTOM

Internal Use Only:

NOTE" SEE AW-014H FOR PRODUCTION VERIFICATION.

- N.B.
1. ASSEMBLY WILL BE BETWEEN EACH OTHER.
 2. BOLT DIA. OF 20 MM WILL BE USED IN ASSEMBLY.

1. ALL DIMENSIONS ARE IN MM UNLESS OTHERWISE STATED
2. UNSPECIFIED DRAFT 3 MIN. AND RADIUS 3 MM. MIN.

	DRAWN BY	CKD. BY	APPD. BY	DRG./ PART NO. LS205H	WEIGHT:- 231 Kgs
NAME				DRG / PART DESCRIPTION LS205H COUNTER WEIGHT	
DATE					
SIGN					
	MATERIAL :- FG200				

REV. NO.	REVISION NOTE	DATE	CKD. BY	APPD. BY	SCALE: NTS	SHEET: 1 of 1
					ALL DIMENSIONS ARE IN MM	